



PEUGEOT BOXER 4X4 DANGEL



INSTRUCTIONS FOR USE AND MAINTENANCE
(In addition to the basic manual)



Dear Client,

We would like to thank you and congratulate you for having chosen a vehicle equipped with a 4 wheel drive system designed and constructed by Automobiles DANGEL.

To help you get the best out of the DANGEL vehicle, this notice covers all the specificities relating to the 4 wheel drive system.

We invite you to read through this instruction booklet before you use the vehicle for the first time.

In this booklet, you will find a multitude of information, details and important advice. These indications will help you to take advantage of the technical qualities and performances offered by the Automobiles DANGEL 4 wheel drive system.

The information relating to the servicing and maintenance of your vehicle's 4 wheel drive equipment can be found at the back of the booklet.

Automobiles DANGEL wishes you an interesting read and great driving.



WARNING



Your vehicle's 4WD equipment vehicle increases its capabilities appreciably and in a known way, thus enabling you to access places where in certain cases of use, a 2-wheel drive version, even with improvements, would not be able to venture.

However, in cases of extreme use (very low adhesion and/or steep slopes in first gear or reverse) at and beyond the limits of the vehicle's capabilities, it will be necessary to adapt your driving to take in account any reaction time necessary for the anti-blocking brake system to interpret the wheel and vehicle speed information. In such conditions of use, deemed excessive, you may experience a furtive sensation of hardening of the brake pedal (for example, on ground with very low adhesion + very strong acceleration + spinning of front and rear wheels or in cross axle situations).

For your safety and to protect the vehicle, as soon as the road conditions become precarious, ensure that you adapt your driving accordingly (see the pages in these instructions on the limits and recommendations for use).

These instructions are provided as a **complement to the basic instructions** for your vehicle and deal only with the specificities of the Automobiles DANGEL 4 wheel drive equipment.

For all other information, see the instructions for the basic vehicle.

We draw your attention...

Your vehicle takes some of the equipments described in this document based on the level of finishing, the version available in the country.





CONTENTS :

RECOMMENDATIONS FOR USE.....	5 to 10
Warning	5
Driving	5
Tyres	9
Washing the vehicle	10
What to do in case of incident	10
IDENTIFICATION OF THE VEHICLE.....	1 to 14
Weights and payloads	12
HOW DOES THE AUTOMOBILES DANGEL 4X4 EQUIPMENT WORK.....	15 to 24
Architecture of the system	15
Operating principle	16
Option locking	19
Frequently asked questions	22
WARRANTY.....	25
Automobiles DANGEL warranty	
SERVICING.....	26 to 28
Who to contact	
Compulsory operations to carry out	
SERVICES.....	29 to 34



RECOMMENDATIONS FOR USE



WARNING



The 4WD equipment designed and constructed by Automobiles DANGEL undoubtedly enhances the driveability of your vehicle, but this does not mean that it is capable of "crossing" uses.

Its improved driveability means that it is suitable exclusively for **off-road (cross-country)** use and **not all-terrain** use.

Failure to comply with the recommendations given in this booklet risks damaging your vehicle and will invalidate our warranty.

Driving

▪ How is the 4WD mode engaged?

Your vehicle is equipped with a self-controlled coupler. It is responsible for transferring a part of the engine torque to the rear axle in the event of the front wheels losing grip. The **changeover to 4WD** takes place silently and smoothly, **entirely automatically with no action on your part** required.

Remark: *When manoeuvring to park (in 1st gear and reverse) and when approaching the steering lock, the movement of vehicle is braked slightly. This **phenomenon is quite normal** and is caused by the different rotation speeds between the front and rear axles.*

Your vehicle is equipped with:

- A self-controlled hydraulic coupler:
the viscous-coupling

- Option, rear axle with limited slip differential.
- Option, rear axle with lockable differential.
- Option, rear axle with limited slip differential and lockable.

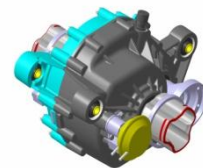

▪ How to drive in all-road?

The cross-country performances of this category of vehicle with a gross vehicle weight (GVW) that can reach 2.95-T are particularly influenced by:

- The load carried, its distribution, and how it is secured
- The adhesion available
- The nature of the ground
- The wear and type of tyres

The ABS system:



Your vehicle is equipped with an ABS system. The aim of this recognised safety equipment is to avoid the wheels blocking according to the adhesion available and to enable you to retain control the trajectory of the vehicle, particularly in the case of emergency braking.

ABS when adhesion is poor:



If in road use the intervention of the anti-locking system is comparable between 2WD and 4WD versions, a 4 wheel drive vehicle enables you to drive on terrain where a 2 wheel drive version, even an improved version, would not be able to cope. Thus on ground with poor adhesion (snow...) or a bumpy road, the anti-locking action can increase stopping distances.

In all cases of cross-country use and when the conditions of adhesion become precarious:

- ☺ Drive slowly and without jerking, in other words drive gently
- ☺ Adapt your speed so that you can negotiate bends and downwards slopes serenely
- ☺ Anticipate your braking taking account of the considerable increase in stopping distances

***Note: NB:** The regulation does not authorise the temporary de-activation of the anti-locking system, so it is therefore completely forbidden to add a device allowing it to be deactivated on demand.*



- **How to drive with a trailer?**

In cross-country use, when you are towing a trailer, you must be aware that:

- ☺ The trailer is not necessarily adapted to cross-country use
- ☺ The choice of stopping places is important, to ensure you can set off again
- ☺ The weight of the trailer and its load may influence the behaviour and the trajectory of your vehicle. You must anticipate.

- **Fording?**

Fording is restricted to the depth of the wheel radius (330 mm) and must remain exceptional.

- **How to negotiate an obstacle?**

To negotiate an obstacle (slight ditch, step,...) we recommend that you:

- ☺ First avoid taking it head on,
- ☺ As far as possible tackle it diagonally,
- ☺ One wheel after the other,
- ☺ Releasing the accelerator before the obstacle.

- **Climbing a slope?**

On a slope:

- ☺ Do not turn round
- ☺ Always stay in the line of the steepest gradient
- ☺ Do not attempt to climb a slope steeper than the **maximum gradient**
- ☺ Always use the engine brake on a downward slope

WARNING

In all cases you must adapt your driving to the situation and anticipate it for your own safety and that of other road users



Useful values in cross-contry:

Front angle	22 - 25 °	
Rear angle	22 - 25 °	
Ventral angle	15 - 16 °	
Ground clearance	195 mm	
wheel radius	330 mm	
Maximum slope	weight	Value in %
	<i>2T (empty)</i>	93 %
	<i>3,5T (in load)</i>	45 %

* Theoretical values given as a rough guide in 1st speed to the regime of maxi couple of the engine (values can vary depending on equipments and wheelbases).





Tyres



▪ Tyre pressure?

The tyres are what bind your vehicle to the ground, so it is important to check their pressure regularly.

Tyres at the right pressure guarantee:

- ☺ Good road holding
- ☺ Moderate fuel consumption
- ☺ Less tyre wear

Reminder: Tyre pressure should be checked when tyres are cold.

Remark:

- The M+S tyres (option) with different characteristics from those of the base vehicle are adapted to off-road situations and road grip changes. It is recommended to consider this feature in normal conditions of use of the vehicle on the road.

- The tyre pressure value is indicated in the instructions manual of the base vehicle or on the sticker on the driver door panel.

Front axle geometry?

-1mm (opening) +/- 1 mm with vehicle in working order.

WARNING

The tyres must always be of the **same make**, the **same type**, and have the **same degree of wear** at the front and rear.

Be careful to **swap the front and rear wheels regularly** according to their degree of wear, **without crossing them**.

Tyre wear directly influences the grip of the vehicle when driving in **precarious conditions** (snow, mud,...).

For such uses, do not hesitate to **replace the tyres early** before reaching the thread wear indicator.

Do not hesitate to choose specialist tyres suited to your use of the vehicle.

Washing the vehicle



After using the vehicle in severe conditions (mud, snow ...), we recommend that you wash your vehicle:

- ☺ Removing the wheels from the vehicle optimises washing
- ☺ Pressure washing is very effective
- ☺ Undercarriage washing is even more effective
- ☺ Check that the protective sheets are not gummed up, dismount if necessary in order to avoid blocking the mobile elements.

If you use a high pressure nozzle, keep a good distance so as to:

- ☺ Protect the painted surfaces
- ☺ Protect the fragile mechanical parts (seals, flexible pipes...)

What to do in case of incident?

Contact an approved dealer of the vehicle's brand specifying that the vehicle is equipped with a 4 wheel drive system by DANGEL (you may present the current notice). In order to facilitate its identification, we suggest that you communicate the equipment number (see page 11).



WARNING

As for most 4WD vehicles, **never tow with the front or rear of the vehicle off the ground** (risk of destroying the transmission).

The Vehicle must be towed with all 4 wheels on the ground (if this is not possible, load it onto a platform).

IDENTIFICATION OF THE VEHICLE:

The vehicle has been equipped by Automobiles DANGEL, and to identify the conversion an identification plate is fixed in the engine compartment (see photo here-under).

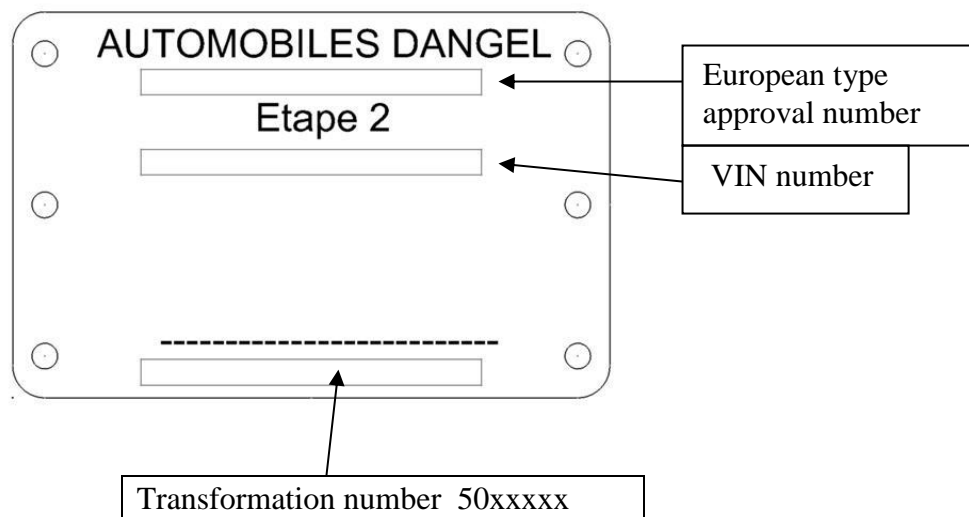

This identification is necessary for the after sales service and the warranty.

Weights and payloads

For more information, refer to your registration certificate.

WARNING

The **payload** values take into account the weight of the DANGEL equipment (approximately 150 Kg).

Your vehicle equipped for 4 wheel drive has improved driveability, but this on no account authorises you to overload it.

In each country it is imperative to respect the allowed towing weights and the allowed speed limits by local laws.



The values of G.C.W.R* and towing charges indicated are for a maximum altitude of 1000 meters, maximum trailer weight must be reduced by 10% in increments of 1000 meters further.

High outside temperatures can cause lower performance of the vehicle. To protect the engine when the outside temperature is above 37 ° C, limit the towed weight.

Note that the loading space and the internal dimensions of the vehicle remain unchanged by the equipment 4X4 (see the instructions manual of the base vehicle for more information).

* G.C.W.R.: Gross Combination Weight Rating

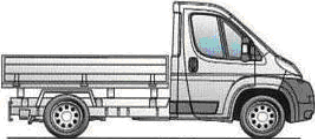
Goods transport :

Engine	SHAPES
2.2 HDI Power 110 HP 81 Kw at 3500 RPM Torque 250 N.m at 1750 RPM	 Flatbeds and double cab flatbeds
2.2 HDI Power 130 HP 96 Kw at 3500 RPM Torque 320 N.m at 2000 RPM	 Van
2.2 HDI Power 150 HP 110 Kw at 3500 RPM Torque 350 N.m at 2000 RPM	



Designation		
Engine	Payload	Wheelbases
S : PUMA 2.2 HDI 110 hp	A : 3000 kg	A : L1 short (3000 mm)
T : PUMA 2.2 HDI 130 hp	B : 3300 kg	B : L2 medium (3450 mm)
U : PUMA 2.2 HDI 150 hp	C : 3500 kg « light »	C : L3 long (4035 mm)
		D : L2S medium long (3800 mm)

Example VIN number: YCSMFB

2nd letter → designation of the payload.

3rd letter → designation of the engine type.

5th letter → designation of the body.

6th letter → designation of the wheelbase.

											Payload (KG)			
Body	Engine			Payload			Wheelbase				Without driver		With driver	
	S	T	U	A	B	C	A	B	C	D	max	min	max	min
F		x	x	x			x				895 à 925	710 à 740	820 à 850	635 à 665
		x	x	x				x			860 à 885	665 à 690	820 à 850	635 à 665
		x	x		x		x				1195 à 1225	1010 à 1040	1120 à 1150	935 à 965
		x	x		x			x			1160 à 1185	965 à 990	1085 à 1110	890 à 915
		x	x		x				x		1085 à 1110	875 à 900	1010 à 1035	800 à 825
		x	x			x	x				1395 à 1425	1210 à 1240	1320 à 1350	1135 à 1165
		x	x			x		x			1360 à 1385	1165 à 1190	1285 à 1310	1090 à 1115
		x	x			x			x		1285 à 1310	1075 à 1100	1210 à 1235	1000 à 1025
		x		x			x				910 à 940	725 à 755	835 à 865	650 à 680
		x		x				x			875 à 900	680 à 705	800 à 825	605 à 630
		x			x		x				1210 à 1240	1025 à 1055	1135 à 1165	950 à 980
		x			x			x			1175 à 1200	980 à 1005	1100 à 1125	905 à 930
		x			x				x		1100 à 1125	890 à 915	1025 à 1050	815 à 840
		x				x	x				1410 à 1440	1225 à 1255	1335 à 1365	1150 à 1180
		x				x		x			1375 à 1400	1180 à 1205	1300 à 1325	1105 à 1130
		x				x			x		1300 à 1325	1090 à 1115	1225 à 1250	1015 à 1040



											Payload (KG)			
Body	Engine			Payload			Wheelbase				Without driver		Body	
	S	T	U	A	B	C	A	B	C	D	max	min	max	min
D Flatbeds		x	x	x			x				975	791	900	716
		x	x	x				x			930	746	855	671
		x	x		x			x			1275	1091	1200	1016
		x	x		x				x		1230	1046	1155	971
		x	x		x					x	1175	991	1100	916
		x	x		x					x	1195	1011	1120	936
		x	x			x	x				1475	1291	1400	1216
		x	x			x		x			1430	1246	1355	1171
		x	x			x			x		1340 à 1375	1156 à 1191	1265 à 1300	1081 à 1116
		x	x			x				x	1395	1211	1320	1136
		x			x			x			990	806	915	731
		x			x				x		945	761	870	686
		x			x					x	910	726	835	651
		x				x		x			990	806	915	731
		x				x			x		1245	1061	1170	986
		x				x				x	1190	1006	1115	931
		x				x				x	1210	1026	1135	951
		x					x	x			1490	1306	1415	1231
		x					x		x		1445	1261	1370	1186
		x					x			x	1390	1206	1315	1161
	x					x			x	1410	1226	1335	1151	
G Double cab flatbeds		x	x		x			x			1120	896	1045	821
		x	x		x				x		1060	836	985	761
		x	x			x		x			1320	1096	1245	1021
		x	x			x			x		1220 à 1260	996 à 1036	1145 à 1185	921 à 961
		x				x			x		1135	911	1060	836
		x				x				x	1075	953	1000	878
		x					x		x		1335	1111	1260	1036
		x					x			x	1235 à 1275	1113 à 1153	1160 à 1200	1038 à 1078

We also equip:

The 4x4 equipment is proposed on the bases vehicles for conversion / convertible (chassis cab, chassis double cab, platform cab and chassis). The weights, sizes and payloads are then functions of the final conversion. The minimum and maximum values must be met according to **Dangel EC Certificate of Conformity (COC)**.

Note that in all cases the 4x4 equipment does not change:

- The volumes as well as the interior dimensions of the loading compartment.
- The bodywork versions.
- The towing weight with braked or unbraked trailer.
- Maximum load at the coupling/ point.

(Refer to the base vehicle's instructions' guide for more information).

HOW DOES THE AUTOMOBILES DANGEL 4x4 EQUIPMENT WORK

Architecture of the system

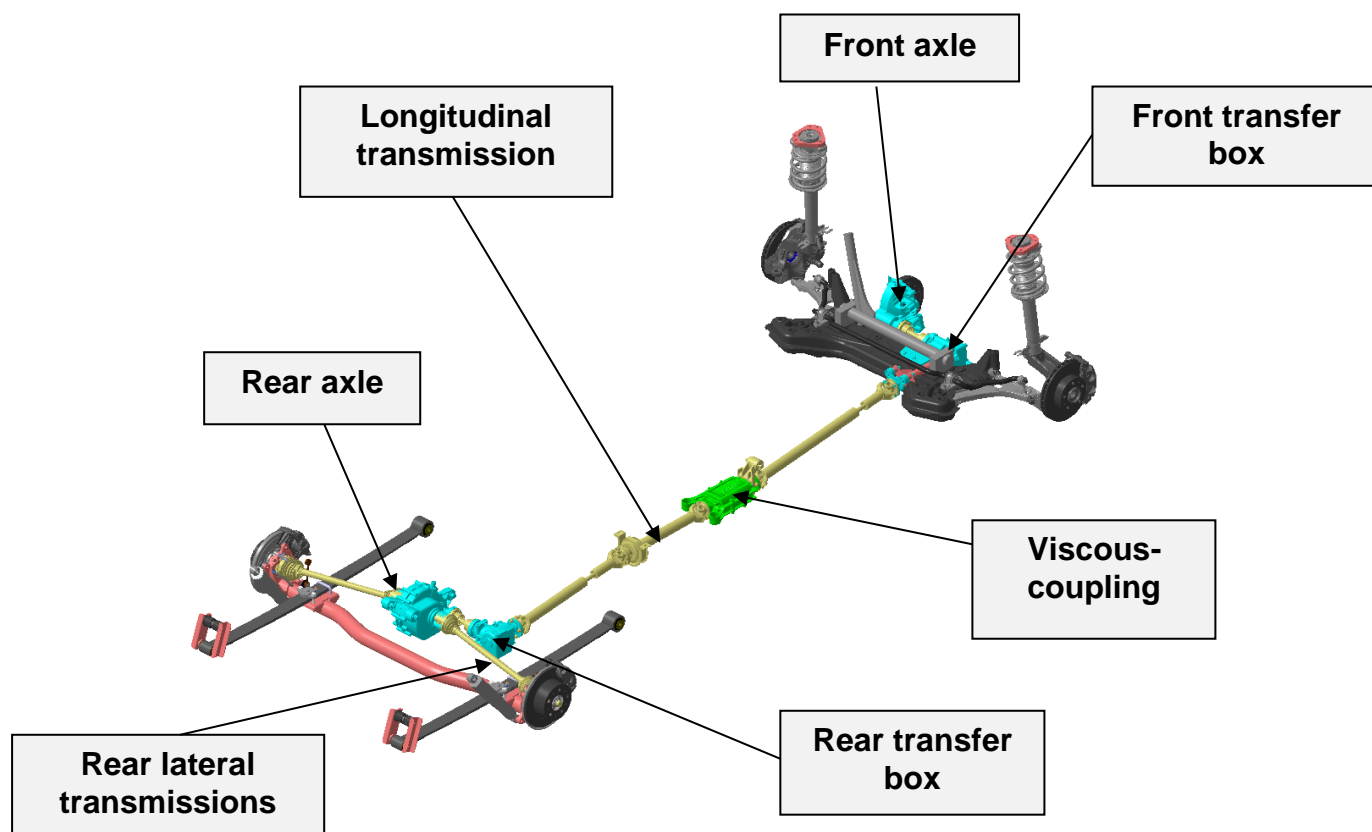

Characteristics of the 4WD Endurance conversion:

- 4x4 transmission with automatic torque transfer by hydraulic coupler
- Total ground clearance of 195 mm when empty in working order (according to the version).
- Speed ratios unchanged
- Original tyres
- Weight of the equipment: approximately 150 kg (according to version).



Operating principle

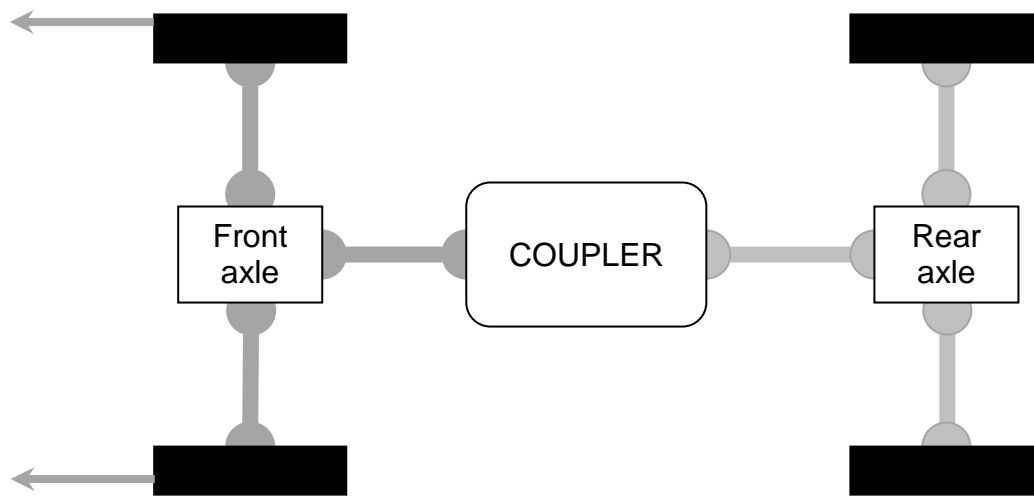

NORMAL OPERATION

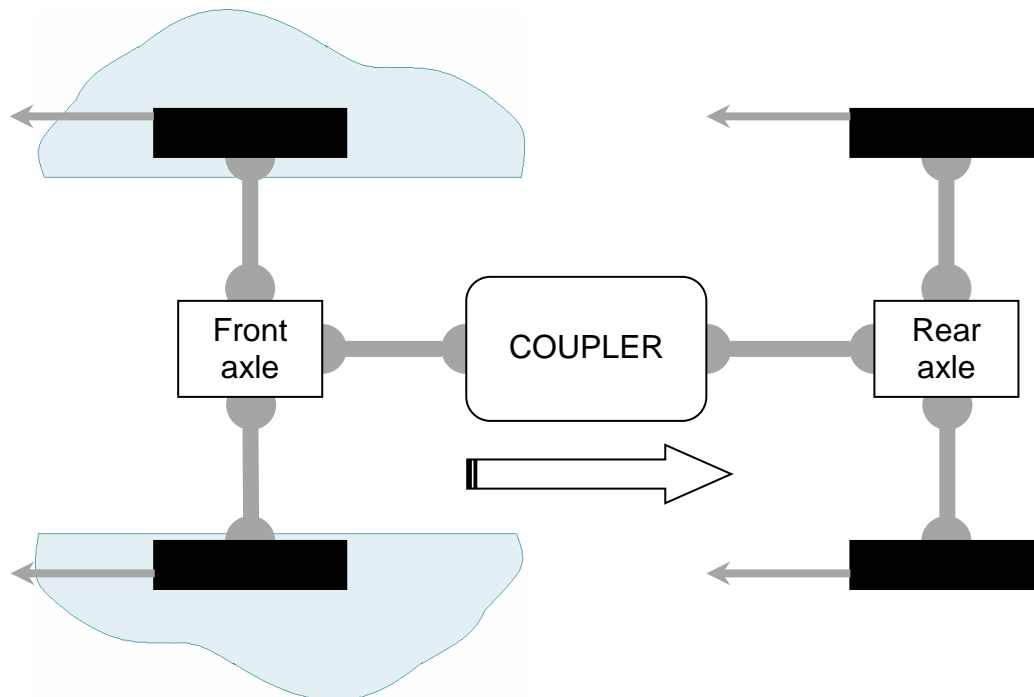

LOSS OF GRIP OF FRONT WHEELS

The operation of the 4 wheel drive system designed and constructed by Automobiles DANGEL is based on **automatic and optimum distribution** of the **engine torque** with the **coupler** at the **heart of the system**.

Depending on the grip of the front axle wheels, the coupler automatically distributes engine torque to the rear axle wheels, thus giving the vehicle **increased driveability**.





Operating principle of the limited slip rear axle (option)

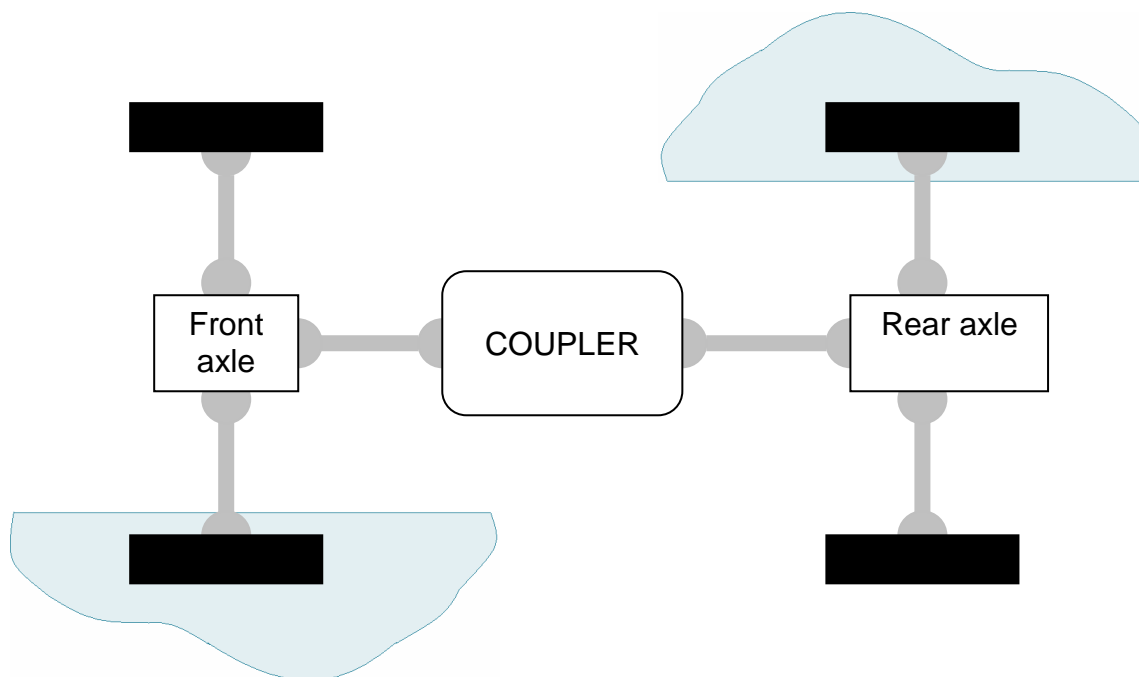

**LOSS OF GRIP OF A REAR WHEEL AND OF A FRONT WHEEL;
FREE REAR AXLE → FORWARD MOVEMENT IS IMPOSSIBLE**

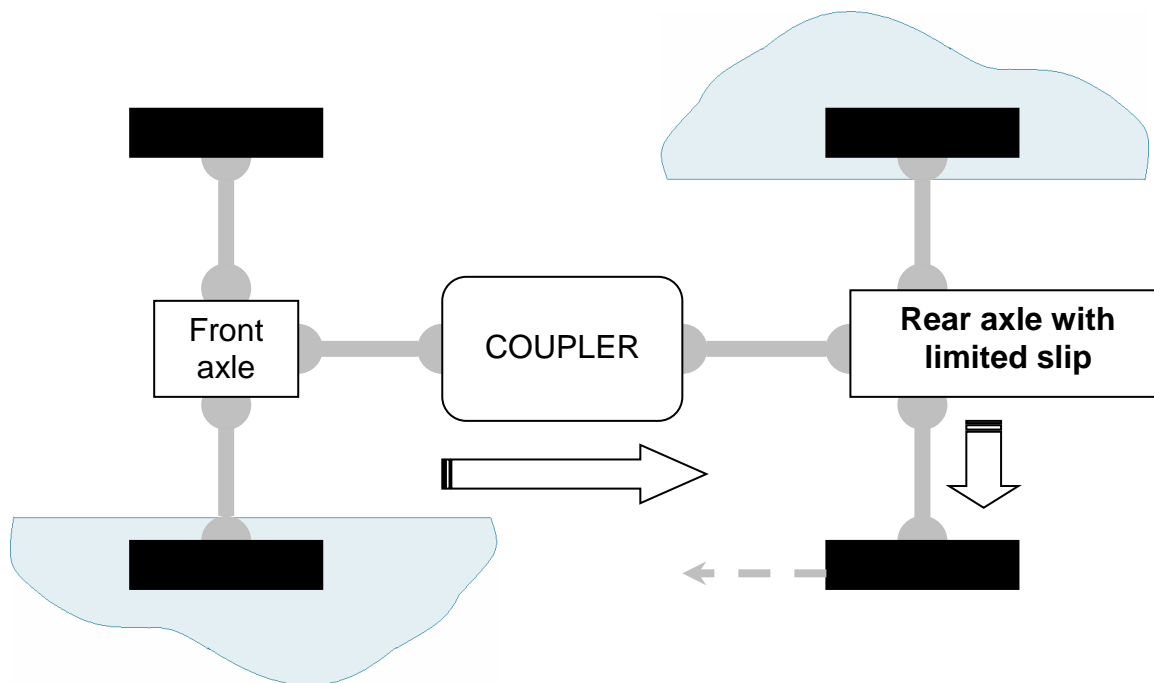

**LOSS OF GRIP OF A REAR WHEEL AND OF A FRONT WHEEL;
REAR LTD SLIP AXLE → FORWARD MOVEMENT IS POSSIBLE
Limited to 80 N.m of torque at the wheel.**



Principle of functioning of the rear axle with lockable and rear axle with limited slip lockable (option)

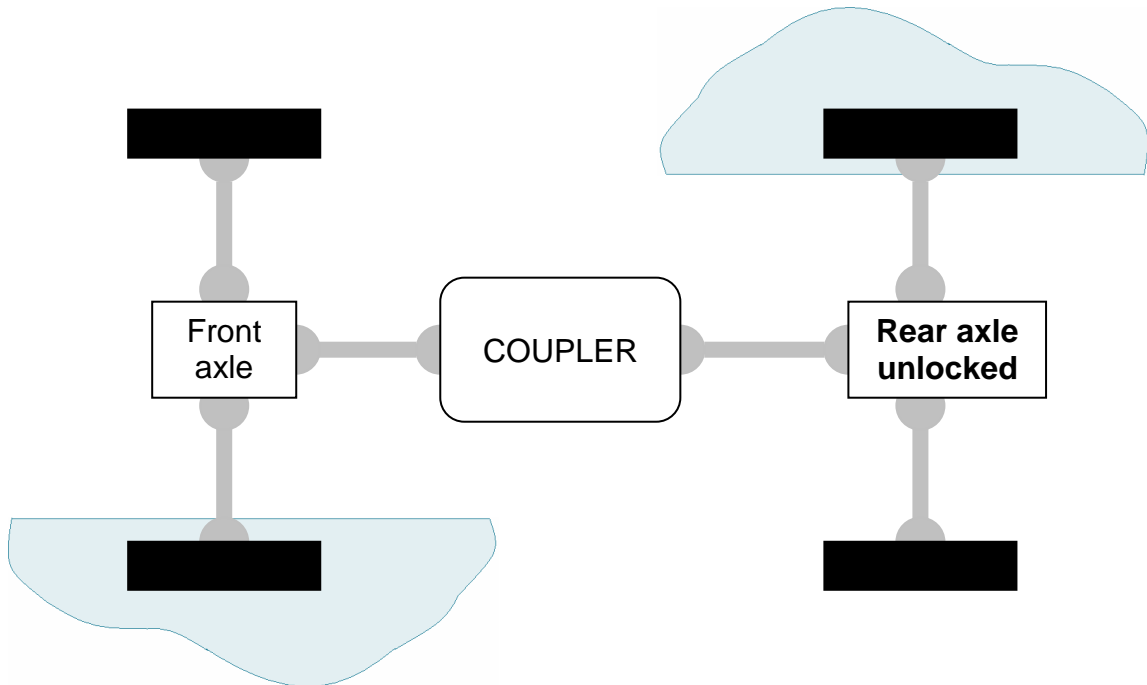

**LOSS OF GRIP OF A REAR WHEEL AND FRONT WHEELS ;
REAR AXLE UNLOCKED → IMPOSSIBLE PROGRESS
REAR LTD SLIP AXLE → LIMITED PROGRESS**

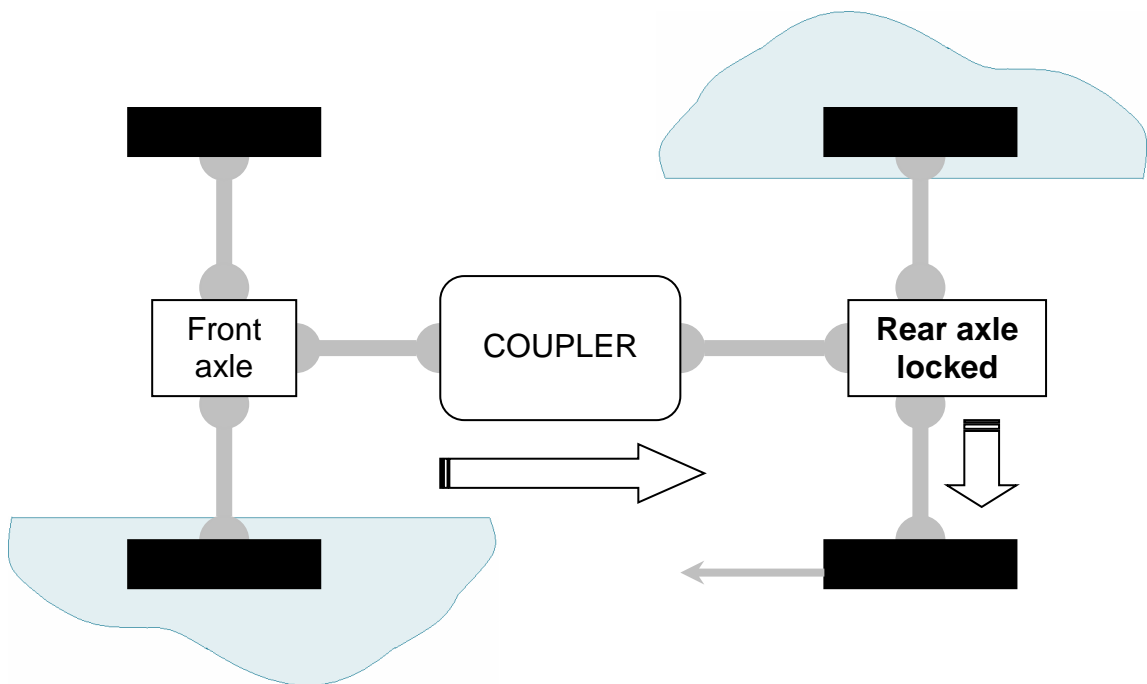

**LOSS OF GRIP OF A REAR WHEEL AND FRONT WHEELS ;
REAR AXLE LOCKED → POSSIBLE PROGRESS**



In free position, the Dangel rear axle distributes the torque symmetrically between the right wheel and the left wheel. Moreover, the differential allows the right rear wheel and the left rear wheel to turn at different speeds. In bends, this guarantees a robust drive performance, and preserves the transmission and tyres.

In the locked position, the Dangel rear axle drives the rear wheels at the same speed, and makes optimum use of the tyre grip. This allows the vehicle to be driven on the most difficult ground : cross axle situations, bumpy, steep rises...

▪ IMPORTANT

The use of the rear differential locking must remain exceptional.

- The rear differential locking system must only be actived on ground with poor grip.
- Do not use the locking system on ground with high adhesion, particularly in bends.
- Do not engage the locking when the wheels are spinning.
- Engage the clutch gently when restarting for the first time.
- Unlock the differential once you have crossed the difficult zone.

Use of the rear differential locking (option)

The rear axle with differential locking increases your vehicle's cross-country capabilities.

Steep bumpy or slippery slopes and cross axle situations can be tackled when the rear differential is locked.

We advise you to lock the rear differential before embarking on the difficult zone.

On a slope or on ground with variable adhesion, proceed gradually so as not to provoke jerking in the transmission. In fact, in this configuration and depending on the nature of the ground, it can happen that all the drive effort is taken over by the only rear wheel which still has some grip.

Do not do U-turns on slopes and ways remain in the line of the greatest slope.





WARNING :

For your safety to guarantee durable use of your vehicle, do not abuse the crossing capabilities, this is not an all terrain vehicle.

▪ **To lock the rear differential**

When stationary or at low speed, press the brown switch on the left of the dashboard to lock the rear differential.

The indicator light above it comes on to confirm that locking has been requested. A buzzer comes on when the differential is actually locked (intermittent audible signal).



For safety reasons, the system prevents locking above 25 kmph.

▪ **To unlock the rear differential**

Press the control switch again to unlock the rear differential.

Remarks:

- Unlocking occurs automatically when the speed exceeds 25 kmph, or after the ignition is switched off.
- When stationary, it is possible that locking will not be instant. If this is the case, simply drive a few metres for the differential to lock.





▪ **Audible and light signals**

In normal operation:

- The indicator light comes on to confirm that locking has been requested.
- A buzzer comes on when the differential is actually locked (intermittent audible signal).

In degraded mode:

- The alarm indicates that there is a fault in the rear differential locking system (long audible signal: 3 seconds approx.).
- A flashing indicator light indicates a fault in the information system.

WARNING

For your safety and to protect your vehicle :

If the locking system is operating in degraded mode, please contact a garage approved by the vehicle's manufacturer.

The fuse for the electrical locking circuit is located underneath the cigar lighter.
Fuse: 10 amp; reference Dangel 99.6.12914.80.

Location of the electrical locking circuit fuse

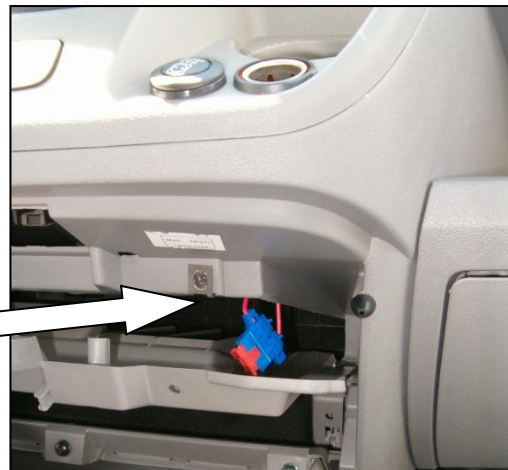

Frequently asked questions

- **Front transfer box**

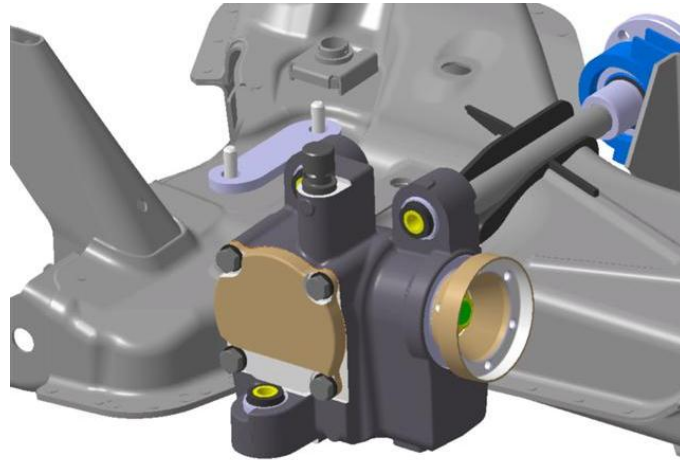

A mechanical assembly transmitting the engine torque to the longitudinal transmission by means of a bevel gear.

- **Longitudinal transmission**

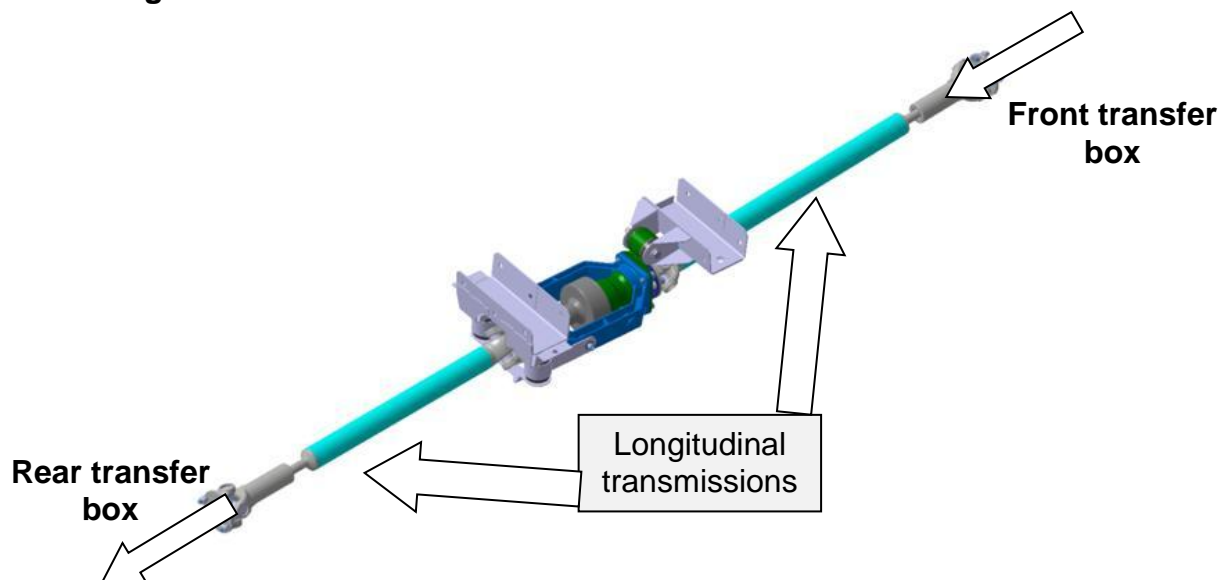

- A mechanical assembly transmitting the engine torque to the rear wheels by means of a coupler.

- **The hydraulic coupler**

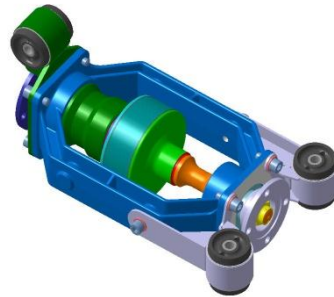

Permanently active, it detects the loss of grip of the front wheels and then transmits the engine torque to the rear wheels.
The coupler will adjust the percentage of torque as required.

- **Rear transfer box**

A mechanical assembly transmitting the engine torque to the rear axle by means of a bevel gear.

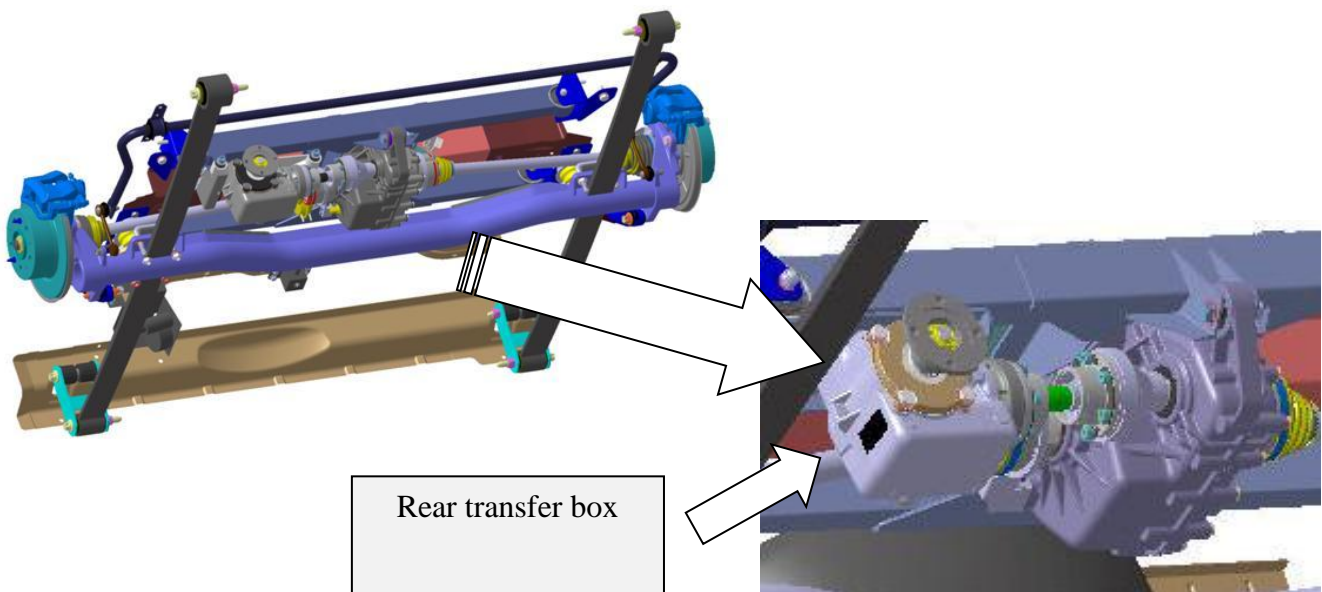

- **Rear axle with differential**

The differential, a mechanical assembly mounted in the rear axle, allows the same wheels on one axle to turn at different speeds (absolute necessity in bends to avoid tyre scrub). It also multiplies the torque.

As an option, the rear differential can be lockable. Locking the rear differential increases your vehicle's cross-country capabilities, but must be used with care.

- **Lateral transmissions (or cardan)**

They transmit the engine torque from the differential to the wheels.

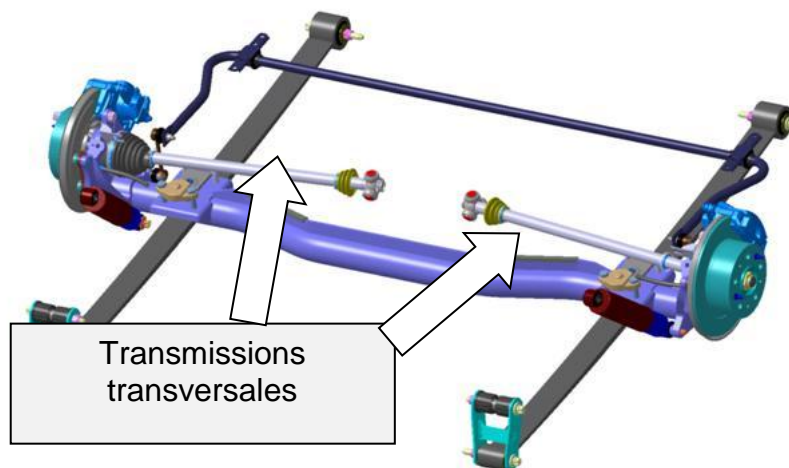



WARRANTY

Conditions of application of the Automobiles DANGEL warranty:

The application of the warranty is subject to the performance of a first oil change technical check (free except for the cost of lubricant) between 1500 and 2500 km.

The warranty certificate (**page 29**) should be returned to us duly completed, accompanied by the invoice for 1.35 hr labour for the 4WD supplements

The warranty service and the periodic maintenance as they are defined in this maintenance book must be performed by a member of the repair network of the make of the vehicle approved to this effect. Only the presence of its stamp on the stub of the book will be accepted as proof.

Automobiles DANGEL equipment must be used for the purposes and payloads for which it is manufactured.

Damage relating to Automobiles DANGEL equipment must not be due to a lack of maintenance or abusive or incorrect use of the vehicle.

WARNING

The 1st OIL CHANGE WARRANTY SERVICE to be done between 1500 and 2500 km is imperative.

Automobiles DANGEL warranty

The Automobiles DANGEL contractual warrant applies in addition to the manufacturer's statutory warranty in the country where it is defined: this manufacturer's contractual warranty remains unchanged and applies in full to the components making up the basic vehicle. At the same time, the Automobiles DANGEL warranty applies only to the components making up the equipment which has been converted or adapted by Automobiles DANGEL.

Conversions and adaptations made by a bodybuilder other than Automobiles DANGEL must in no way alter the technical characteristics of the vehicle as it is delivered (compliant with this booklet) and in no way alter its use as defined.

Automobiles DANGEL reserves the right to invalidate the warranty of a vehicle that has been converted or adapted by another bodybuilder insofar as this modification does not meet the conditions mentioned above.

The warranty applies as from the 1st day when the vehicles effectively go into service. The parts specific to the Automobiles DANGEL equipment and the corresponding labour are guaranteed for 2 years, subject to compliance with the recommendations for use and the maintenance plan.

SERVICING :

Contact a repairer certified by the manufacturer while informing him that the vehicle is equipped with a DANGEL 4-wheel drive system (hand this manual to him if required), and refer to the detailed recommendations on the following pages.



In case of extreme uses (heavy loads, all-road driving, motorway etc.) the mechanical elements of your vehicle are more stressed and need more frequent maintenance.

Who to contact ?

	Maintenance and repairs must be done in the after sales network of the make of your vehicle.
---	---

CONTENT OF SERVICES:

To make during every revision as a supplement to the check list of the basic vehicle 4x2:

OPERATIONS	PARTS	LUBRICANTS
 Oil change	Front transfer box Rear transfer box Rear axle	Oil 80 w 90 API GL5 -Yacco Bvx Ls 200 Compatible oils: 80W90 according to standard API GL5 ZF TE-ML05C
 Control	- state of the rear transmission sheaths - absence of leaks on transfer boxes and rear axle housings	
	- sliding transmissions	-Lubrication at each maintenance check or once-a year. (see « Mandatory maintenance operations » longitudinal transmission)

Remark:

*To maintain the performances and the integrity of your equipment, **it is imperative that the qualities and quantities of oil recommended be used.***

Compulsory operations to carry out



Front transfer box



1st warranty oil change: 1500 to 2500 km

Quantity: 0.45 l

Oil: 80 W 90 API GL5 (YACCO BVX LS 200), equivalence **80W90** according to standard **API GL5 ZF TE-ML05C**

Oil change: Every 24.000 km or 2 years in case of normal use, every 18.000 km or 1 year in case of intensive/ severe use.

The filling plug does not indicate the oil level

Oil change plug

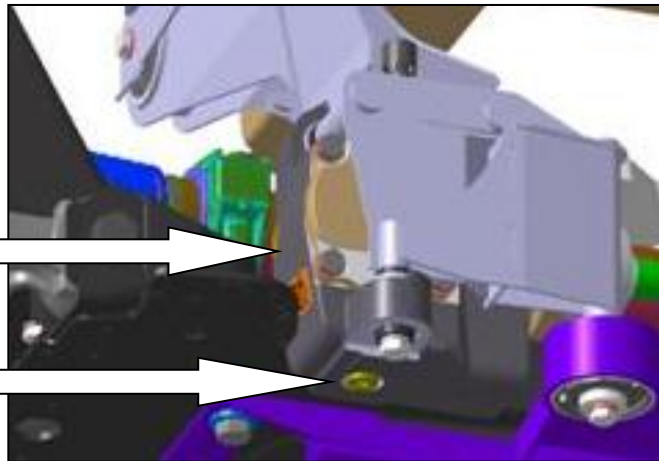

Rear transfer box



1st warranty oil change: 1500 to 2500 km

Quantity: 0.50 l

Oil: 80 W 90 API GL5 (YACCO BVX LS 200), equivalence **80W90** according to standard **API GL5 ZF TE-ML05C**

Oil change: Every 24.000 km or 2 years in case of normal use, every 18.000 km or 1 year in case of intensive/ severe use.

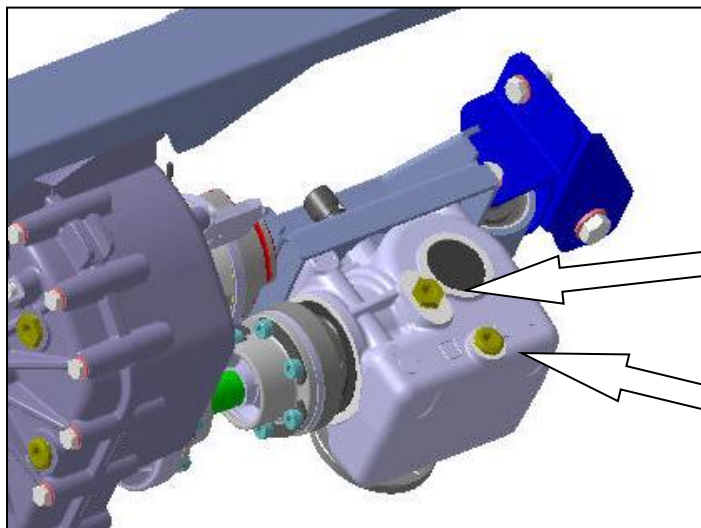

The filling plug does not indicate the oil level

Oil change plug



 **Rear axle**

 **1st warranty oil change:** 1500 to 2500 km

Quantity: 1.20 l

Oil: 80 W 90 API GL5 (YACCO BVX LS 200), equivalence **80W90** according to standard API GL5 ZF TE-ML05C

Oil change: Every 24.000 km or 2 years in case of normal use, every 18.000 km or 1 year in case of intensive/ severe use.

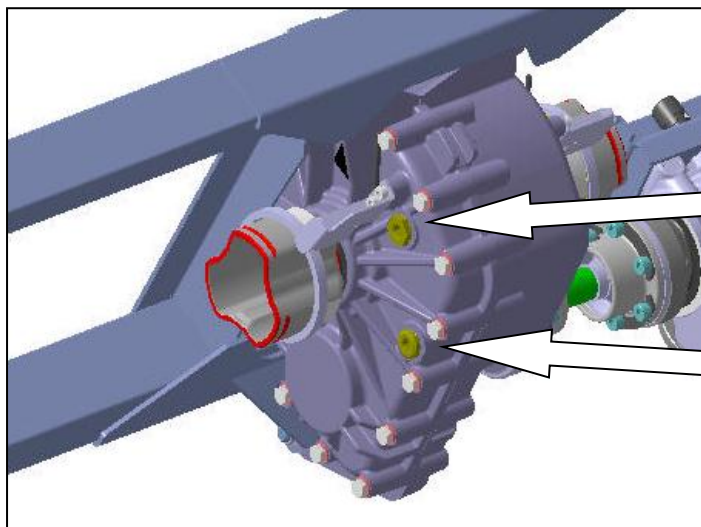

The filling plug does not indicate the oil level

Oil change plug

 **Gearbox**

Consult the manufacturer's recommendations.

 **Longitudinal transmission**

 Lubricate the crosspieces* during the 4-wheel-drive maintenance or once a year.

*: crosspieces presence depends on transmission models.

 **The hydraulic coupler**

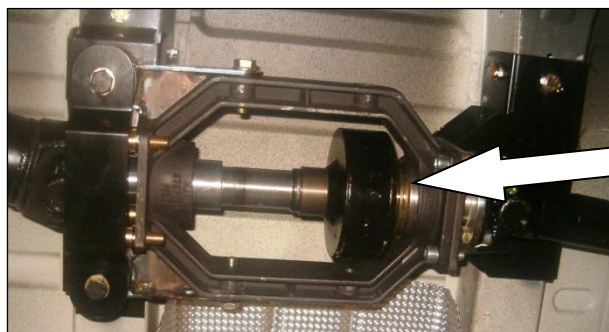

Hydraulic coupler



**THE 1st WARRANTY SERVICE IS COMPULSORY TO
VALIDATE THE DANGEL WARRANTY**

Warranty certificate



Date :

Km :

VIN N° :

Start warranty date :

Stamp of the dealer or garage :

A copy of this page completed by the authorised repairer for your make of vehicle should be sent to Automobiles DANGEL after the vehicle has been serviced.





<p style="text-align: center;">1500 – 2500 KM SERVICE</p> <p>DATE:</p> <p>Km:</p> <p>Remark:</p>	<p style="text-align: center;">APPROVED GARAGE STAMP</p>
<p style="text-align: center;">SERVICE 24.000 KM</p> <p>DATE : ____ / ____ / ____</p> <p>Next service on _____ or _____ km</p>	<p style="text-align: center;">APPROVED GARAGE STAMP</p>
<p style="text-align: center;">SERVICE 48.000 KM</p> <p>DATE : ____ / ____ / ____</p> <p>Next service on _____ or _____ km</p>	<p style="text-align: center;">APPROVED GARAGE STAMP</p>

USE THE QUALITIES OF OIL RECOMMENDED





<p style="text-align: center;">SERVICE 72.000 KM</p> <p>DATE : ____ / ____ / ____</p> <p>Next service on _____ or _____ km</p>	<p style="text-align: center;">APPROVED GARAGE STAMP</p>
<p style="text-align: center;">SERVICE 96.000 KM</p> <p>DATE : ____ / ____ / ____</p> <p>Next service on _____ or _____ km</p>	<p style="text-align: center;">APPROVED GARAGE STAMP</p>
<p style="text-align: center;">SERVICE 120.000 KM</p> <p>DATE : ____ / ____ / ____</p> <p>Next service on _____ or _____ km</p>	<p style="text-align: center;">APPROVED GARAGE STAMP</p>

USE THE QUALITIES OF OIL RECOMMENDED





<p style="text-align: center;">SERVICE 144.000 KM</p> <p>DATE : ____ / ____ / ____</p> <p>Next service on _____ or _____ km</p>	<p style="text-align: center;">APPROVED GARAGE STAMP</p>
<p style="text-align: center;">SERVICE 168.000 KM</p> <p>DATE : ____ / ____ / ____</p> <p>Next service on _____ or _____ km</p>	<p style="text-align: center;">APPROVED GARAGE STAMP</p>
<p style="text-align: center;">SERVICE 192.000 KM</p> <p>DATE : ____ / ____ / ____</p> <p>Next service on _____ or _____ km</p>	<p style="text-align: center;">APPROVED GARAGE STAMP</p>

USE THE QUALITIES OF OIL RECOMMENDED





<p style="text-align: center;">SERVICE 216.000 KM</p> <p>DATE : ____ / ____ / ____</p> <p>Next service on _____ or _____ km</p>	<p style="text-align: center;">APPROVED GARAGE STAMP</p>
<p style="text-align: center;">SERVICE 240.000 KM</p> <p>DATE : ____ / ____ / ____</p> <p>Next service on _____ or _____ km</p>	<p style="text-align: center;">APPROVED GARAGE STAMP</p>
<p style="text-align: center;">SERVICE 264.000 KM</p> <p>DATE : ____ / ____ / ____</p> <p>Next service on _____ or _____ km</p>	<p style="text-align: center;">APPROVED GARAGE STAMP</p>

USE THE QUALITIES OF OIL RECOMMENDED





Note





Note





PEUGEOT



AUTOMOBILES DANGEL S.A.

5, RUE DU CANAL - F 68780 SENTHEIM

TÉL. : +33 (0)3 89 38 57 00

FAX : +33 (0)3 89 82 59 13

INTERNET : www.dangel.com

Copying or translation even partial forbidden without the prior written consent of S.A. Automobiles DANGEL.

The manufacturer reserves the right to modify his production, without having to update the present notice.

